

# Multifunction board, optically isolated, 16/8 SE or 8/4 diff. inputs, 4 analog outputs, 12-/16-bit

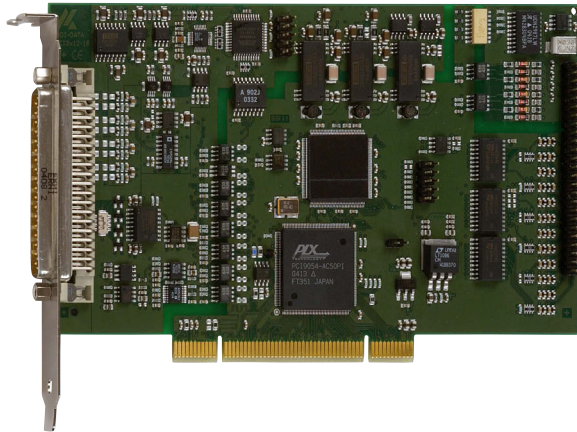

## APCI-3110 / APCI-3116

PCI 3.3 V or 5 V

Optical isolation 1000 V

16/8 SE or 8/4 diff. inputs

12-bit or 16-bit resolution, 200 kHz

PCI DMA, programmable gain

4 analog outputs, 12-bit

Timer/counter/watchdog

8 optically isolated dig. I/O, 24 V, 24 TTL I/O

### Features

- PCI 3.3 V or 5 V

#### Analog inputs

- 16/8 SE or 8/4 diff. inputs, optically isolated
- Resolution: 12-bit (APCI-3110) or 16-bit (APCI-3116)
- Throughput: 200 kHz
- Input voltage: 0-10 V,  $\pm 10$  V, 0-5 V,  $\pm 5$  V, 0-2 V,  $\pm 2$  V, 0-1 V,  $\pm 1$  V, 0-20 mA (option), freely programmable through software for each channel
- Current inputs: 0-20 mA (Option) can be combined freely with voltage inputs
- Gain PGA x1, x2, x5, x10 freely programmable through software for each channel

#### Analog acquisition

- Different input modes:
  - 1) Simple mode
  - 2) Scan modes
  - 3) Sequence modes
  - 4) Auto Refresh mode
- Onboard FIFO (for 512 analog values)
- PCI-DMA for analog data acquisition

#### Analog outputs

- 4 analog outputs, optically isolated
- 12-bit resolution
- Setup time 15  $\mu$ s typ
- Output voltage after reset: 0 V
- Each output has its own ground line (without optical isolation)
- Output voltage range: -10 V up to + 10 V
- Output current:  $\pm 5$  mA
- Short-circuit current:  $\pm 20$  mA

#### 24 V digital I/O

- 24 V digital I/O enable a high interference distance and a long distance between signal transmitter and data acquisition
- 4 digital inputs, 24 V, optically isolated
- 4 digital outputs, 24 V, optically isolated

#### TTL I/O

- 24 digital TTL inputs/outputs
- Port0: outputs / Port1: inputs / Port2: I/O
- All I/O are at 5 V through pull-up resistors
- Easy programming through I/O read and write commands

#### Timer/counter

- 3 / 3, 16-bit

#### Watchdog

- 2, 16-bit

### Safety features

- Optical isolation 1000 V min.
- Creeping distance IEC 61010-1
- Circuit part of the analog acquisition is separated from the circuit part of the digital function
- Overvoltage protection  $\pm 40$  V
- Protection against high-frequency EMI
- Input filters
- Noise neutralisation of the PC supply
- Connection of the I/O signals through robust industry-standard D-Sub connector

### Applications

- Industrial process control
- Industrial measurement and monitoring
- Multichannel data acquisition
- Control of chemical processes
- Factory automation
- Acquisition of sensor data
- Laboratory equipment
- Current measurement
- Instrumentation

### Software

#### Standard drivers for:

- Linux
- 32-bit drivers for Windows 8 / 7 / Vista / XP / 2000
- Signed 64-bit drivers for Windows 8 / 7 / XP
- Real-time use with Linux and Windows on request

#### Drivers and samples for the following compilers and software packages:

- .NET
- Microsoft VC++ • Borland C++ • Visual Basic
- Delphi • LabVIEW • LabWindows/CVI

#### ADDPACK functions:

Analog input • Analog output • Digital input  
Digital output • Watchdog • Timer • Counter

#### On request:

Further operating systems, compilers and samples.

Driver download: [www.addi-data.com](http://www.addi-data.com), download menu



PCI 32-bit



Windows  
64/32-bit drivers



LabVIEW™



LabWindows/CVI™



**Customer-tailored modifications**  
designed

to suit your needs.  
Hardware and software,  
firmware, PLDs, ...  
Contact us!

## Specifications

### Analog inputs

Number of inputs:	16/8 SE or 8/4 differential inputs
Resolution:	12-bit (APCI-3110) or 16-bit (APCI-3116)
Optical isolation:	1000 V through opto-couplers from PC to peripheral
Input ranges:	Software-programmable for each channel 0-10 V, ±10 V, 0-5 V, ± 5 V, 0-2 V, ± 2 V, 0-1 V, ± 1 V 0-20 mA optional
Gain:	Software programmable (x1, x2, x5, x10)
Throughput:	200 kHz
Trigger:	through software, timer, external event (24 V input)
Data transfer:	Data to the PC through FIFO memory, Interrupt at EOC (End Of Conversion), DMA transfer at EOC
Interrupts:	End of conversion, at timer overrun, End of scan

### Analog outputs

Number of outputs:	4
Optical isolation:	1000 V through opto-couplers
Resolution:	12-bit
<b>Voltage outputs</b>	
Output range:	-10 V to +10 V (-1 LSB)
LSB:	4.8828 mV
Accuracy:	11-bit
Time to Ready:	typ. 4.5 µs
Setup time:	typ 15 µs (at 10 V step)
Max. output current:	± 5 mA
Short-circuit current:	± 20 mA
Output voltage after reset:	0 V

### Digital I/O

Number of I/O channels:	4 digital inputs, 24 V 4 digital outputs, 24 V
Logical "0" level:	0-14 V
Logical "1" level:	19-30 V
Optical isolation:	1000 V through opto-couplers from PC to peripheral

### TTL I/O

Number of TTL I/O channels:	24
I/O Address range:	128 Byte, addressing : 32-bit
Programming:	Through write/read commands

### EMC – Electromagnetic compatibility

The product complies with the European EMC directive. The tests were carried out by a certified EMC laboratory in accordance with the norm from the EN 61326 series (IEC 61326). The limit values as set out by the European EMC directive for an industrial environment are complied with. The respective EMC test report is available on request.

### Physical and environmental conditions

Dimensions:	175 x 99 mm
System bus:	PCI 32-bit 3.3/5V acc. to spec. 2.2 (PCISiG)
Space required:	1 PCI slot for analog I/O, 1 slot opening for digital I/O with FB8001
Operating voltage:	+5 V, ±5 % from the PC
Front connector:	37-pin D-Sub male connector
Additional connector :	50-pin male connector for connecting the dig. I/O
Temperature range:	0 to 60 °C (with forced cooling)

### APCI-3110 / APCI-3116

Multifunction board, optically isolated, 16/8 SE or 8/4 diff. inputs, 4 analog outputs, 12-/16-bit. Incl. technical description and software drivers.

#### Versions

- APCI-3110-16:** 16 SE/8 diff. inputs, 4 analog outputs, 12-bit
- APCI-3110-8:** 8 SE/4 diff. inputs, 4 analog outputs, 12-bit
- APCI-3116-16:** 16 SE/8 diff. inputs, 4 analog outputs, 16-bit
- APCI-3116-8:** 8 SE/4 diff. inputs, 4 analog outputs, 16-bit

#### Options

Please indicate the number of channels

- Option SF:** Precision filter for 1 single-ended channel
- Option DF:** Precision filter for 1 diff. channel
- Option PC:** Current input 0(4)-20 mA for 1 channel  
**PC-SE:** for Single-ended **PC-Diff:** for differential

### Simplified block diagram

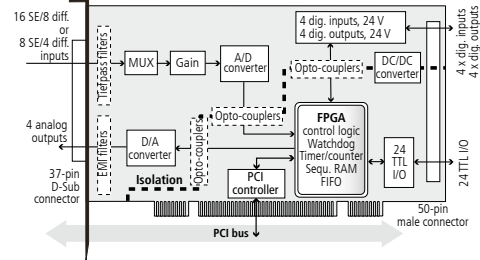

### Pin assignment – 37-pin D-Sub male connector

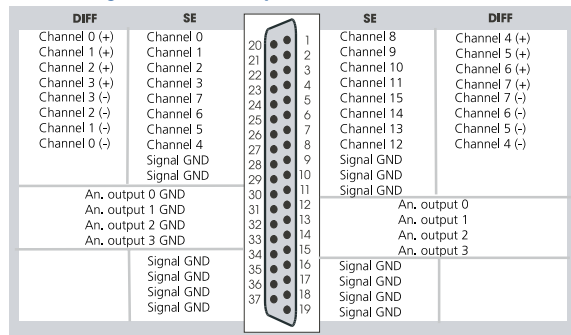

### Pin assignment – 50-pin male connector

Assignment	Pin	Assignment	Assignment	Pin	Assignment
Output 3	1	Input 3+	TTL 22	31	TTL 6
Input 3-	2	Output 2	TTL 13	32	TTL 21
Input 2+	3	Input 2-	TTL 5	33	TTL 12
Output 1	4	Input 1+	TTL 20	34	TTL 4
Input 1-	5	Output 0	TTL 11	35	TTL 19
Input 0+	6	Input 0-	TTL 3	36	TTL 10
GND 0	7	+24 V	TTL 18	37	TTL 2
Not connected	8	Not connected	TTL 9	38	TTL 17
GND	9	GND	TTL 1	39	TTL 8
TTL 15	10	TTL 23	TTL 16	40	TTL 0
TTL 7	11	TTL 14			

### ADDI-DATA connection

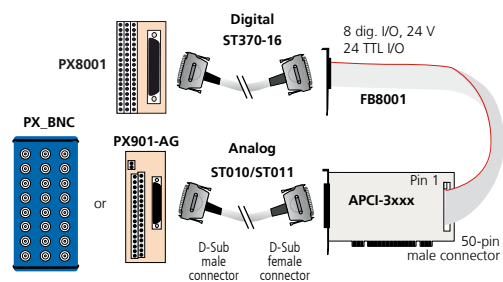

## Ordering information

#### Accessories

- PX901-A:** Screw terminal panel with transorb diodes for connecting the analog I/O
- PX901-AG:** Same as PX901-A with housing for DIN rail
- PX\_BNC:** BNC connection box for connecting the analog I/O
- ST010:** Standard round cable, shielded, twisted pairs, 2 m
- ST011:** Standard round cable, shielded, twisted pairs, 5 m
- PX8001:** 3-row screw terminal panel, 50-pin, for DIN-rail mounting
- FB8001:** Ribbon cable for digital I/O
- ST370-16:** Standard round cable, shielded, twisted pairs, 2 m