

Motion control for servo or stepper motors

New!*

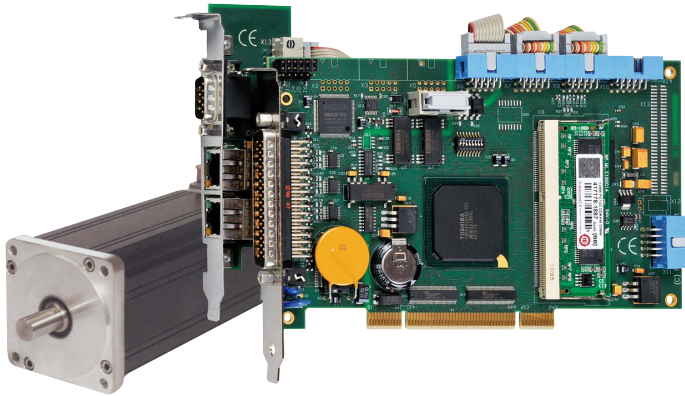

PCI 32-bit



Windows
64/32-bit drivers



The board APCI-8008 for the PCI bus is used for the control of up to 8 servo or stepper motor axes through a PC. With this intelligent and flexible board, many control tasks from simple to complicated can be realised.

The board has three stepping/direction output channels (D/A channels, 16-bit). They are optically isolated from the digital current supply and are used for the control of commercially available power amplifiers connected as speed controlling devices or current regulators.

Incremental encoders, SSI encoders and EnDat encoders as well as end and reference switches can be connected to each axis channel.

Digital PID filters with forward compensation and optional Notch filters are also involved in the axis control.

The "open" controlling concept of the APCI-8008 is intended in the first place for manufacturers of special-purpose machines and users who need a flexible integration as well as a CNC solution.

Features

Hardware/properties

- Intelligent board based on a 64-bit RISC processor
- Positioning of up to 3 axes either with servo or stepper motors. Mixed operating of servo and stepper motors possible. Up to 8 axes with slave board
- Interface for commercially available power amplifiers
- All input and output channels are optically isolated
- A multiple-axis system can be realised by inserting several APCI-8008 in the same PC.
- 2 Ethernet interfaces incl. one which can be used as an EtherCAT interface.

Software

- Linear, circular, helical, spline and CAD interpolation
- Point-to-point movement with independent control of each axis
- Function library for .NET, Pascal, C-Basic, Borland Delphi, Borland C++, Visual Basic, Visual C++, LabVIEW
- Programming through a PC application software or stand-alone (a compiler similar to pascal is supplied with the board)
- The operating program can be easily adapted to specific requirements using program modules supplied with the board (e.g. GEAR, SCANNER, ELCAM)



Customer-tailored modifications

designed to suit your needs.
Hardware and software,
firmware, PLDs, ...

Contact us!

APCI-8008

For 3 servo or stepper motors

Onboard 64-bit RISC processor

Ethernet/EtherCAT interfaces

Incremental encoder, SSI or EnDat 2.2

16-bit analog output channels

Can be extended to a total of 8 axes

- User programs created with the compiler can be processed automatically
- Multitasking: the board can simultaneously process up to 4 user programs.

Applications

- Motion control and position measurement (e.g. optical component measurement)
- Laser processing machines
- Bonding robots
- Water-jet cutting machines
- Tube bending machines
- Tube welding machines
- Component mounting machines (SMD)
- Fibreglass wrapping devices
- Handling systems for analysis technology
- Machines for contact lens production
- Stud welding machines
- Machines for processing dental prostheses
- Production quality control
- Cutting-to-length devices with flying saw

Software

Standard drivers for:

- Linux
- 32-bit drivers for Windows 8 / 7 / Vista / XP / 2000
- Signed 64-bit drivers for Windows 8 / 7 / XP
- Real-time use with Linux and Windows on request

Drivers and samples for the following compilers and software packages:

- Microsoft C Lib. • Borland C Lib.
- Visual Basic • Visual C++ • Delphi
- LabVIEW

Supplied with the board: McuWIN user interface

On request:

Other operating systems, compilers and samples

Driver download: www.addi-data.com/downloads

* Preliminary
product information

Specifications*

APCI-8008

CPU system:	64-bit-RISC processor 333 MHz
RAM:	64 MB / Flash 32 MB (1 GB optional)
Data exchange with the PC:	Through PCI bus
Controller software:	PIDF (PID filters with forward compensation)
Interpolation:	2D .. 3D linear, 2D circular, 3D circular, 3D helix, spline, asynchronous and synchronous interpolation with secondary axes. With OPMF-8008 all interpolations 2D .. 8D depending on the number of axes
Inputs for incremental encoders:	Diff. or TTL max. 16 MHz Word length: 32-bit with sign Short-circuit and line break protection
Inputs for SSI encoders:	Up to 32-bit, Gray / binary code, variable frequency 30 kHz to 2 MHz
Inputs for EnDat:	EnDat 2.2 up to 4 MHz
Setpoint value outputs (servo):	4 D/A converters, 16-bit resolution, ± 10 V
Pulse outputs (stepper motors):	1 stepper signal (RS422) and 1 directional signal (RS422) for each channel, pulse frequency up to 2 MHz
Isolated digital inputs:	16 inputs, 24 V, as end, reference switch or freely programmable
Isolated digital outputs:	8 channels, 24 V / 500 mA, for releasing the power amplifiers or freely programmable
Ethernet (option):	2 x Ethernet, 10/100 MBit
Interrupts:	Through PCI BIOS
DMA:	Bus master
Auxiliary voltage:	24 V external for digital I/O, 5 V, 1.1 A

Safety

Optical isolation: 1000 V

EMC – Electromagnetic compatibility

The product complies with the European EMC directive. The tests were carried out by a certified EMC laboratory in accordance with the norm from the EN 61326 series (IEC 61326). The limit values as set out by the European EMC directive for an industrial environment are complied with. The respective EMC test report is available on request.

Physical and environmental conditions

Dimensions:	175 x 106 mm
System bus:	PCI 32-bit 3.3/5 V acc. to spec. 2.2 (PCISIG)
Space required:	Board APCI-8008: 1 PCI slot Slave board OPMF: 1 PCI slot Cable FB8008: 1 slot opening
Operating voltage:	+ 5 V ± 5 % from the PC
Front connector APCI-8008:	Axis 1, 2, 3: 50-pin D-Sub male connector
Front connector OPMF-8008:	Axis 4, 5, 6: 50-pin D-Sub male connector
Ribbon cable FB8008:	Axis 7, 8: 50-pin D-Sub male connector
Temperature range:	0 to 60 °C (with forced cooling)

APCI-8008: Motion control board for servo or stepper motors. 16 dig. inputs and 8 dig. outputs, 24 V, optically isolated.

Incl. technical description, software drivers.

APCI-8008-STP: same as APCI-8008, only for stepper motors

Options: All options begin with OPMF-8008. Please complete with the following option name:

- Basis:** Mezzanine board for the extension with -AI16-4, -AO and -DIO (only up to 3 axes)
- 4A-SRV/-4A-STP:** 4th axis – 8 inputs and 4 dig. outputs in addition
- 5A-SRV/-5A-STP:** 5th axis – 16 inputs and 8 dig. outputs in addition
- 6A-SRV/-6A-STP:** 6th axis – 16 inputs and 8 dig. outputs in addition
For the option -7A and more the FB8008 cable is required
- 7A-SRV/-7A-STP:** 7th axis – 24 inputs and 12 dig. outputs in addition
- 8A-SRV/-8A-STP:** 8th axis – 24 inputs and 12 dig. outputs in addition
- AI16-4:** 4 analog inputs (option available in single or double, max. 8 analog inputs), 16-bit resolution.
- ETH:** Mezzanine board for the connection of 2 Ethernet interfaces (Standard Ethernet / EtherCAT)
- DIO:** 8 digital inputs and 4 dig. outputs, opt. isolated (option available up to 3 times, max. 24 inputs and 12 outputs)
- AO:** 1 analog output, option available up to 5 times (max. 8 analog outputs)
(output is only free when the axis is not used)
- OPT.CAN-8008:** CAN bus connection of the APCI-8008 (not CAN Open).

Simplified block diagram

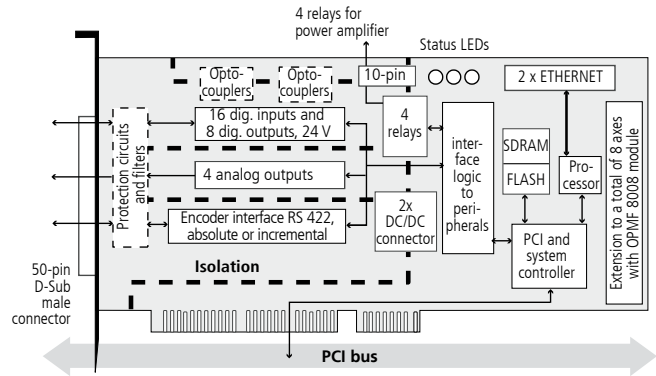

Pin assignment – 50-pin D-Sub male connector

Pin	Pin	Pin	Pin
34	Setpoint value 3 /step 3	18	Setpoint value 2/step 2
35	Setpoint value 3 /step 3	19	Setpoint value 2/step 2
36	True value 3	20	True value 2
37	True value 3	21	True value 2
38	True value 3	22	True value 2
39	True value 3	23	True value 2
40	True value 3 /step 3	24	True value 2/step 2
41	True value 3 /step 3	25	True value 2/step 2
42	Dig. input 9	26	Dig. output 1
43	Dig. input 10	27	Dig. output 2
44	Dig. input 11	28	Dig. output 3
45	Dig. input 12	29	Dig. output 4
46	Dig. input 13	30	Dig. output 5
47	Dig. input 14	31	Dig. output 6
48	Dig. input 15	32	Dig. output 7
49	Dig. input 16	33	Dig. output 8
50	0 V ext. for dig. I/O		

ADDI-DATA connection

Example for an 8-axes system
APCI-8008: Standard 1 up to 3 axes
OPMF/8A: 5 axes, including 3 on the 50-pin front connector and 2 on the connector for ribbon cable FB8008

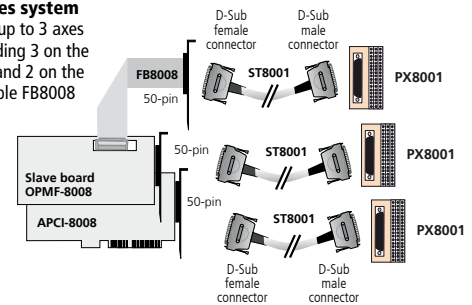

Ordering information

Accessories:

- FB-CAN:** Ribbon cable between OPMF and 9-pin D-Sub male connector with bracket for connecting the CAN bus.
- FB-INTERBUS:** Ribbon cable between OPMF and 9-pin D-Sub male connector with bracket for connecting the INTERBUS.
- FB8008:** From the 1st axis on for connecting the analog inputs (option OPMF-8008-AI16-4). Ribbon cable between OPMF and a 50-pin D-Sub male connector with bracket. On request with female connector.
- FB8008_50_25:** From the 4th axis on for connecting the analog inputs (OPMF-8008-AI16-4) or from the 7th axis on (OPMF/7; OPMF/8) for connecting additional axes. Ribbon cable between OPMF and D-Sub male connector on bracket and the 25-pin D-Sub for the connecting the relays.
- FBRELAY:** For releasing the relays
FBRELAY_9: Standard, 9-pin cable with bracket
FBRELAY_25: more than 3 axes: 25-pin cable.
- PX8001:** 3-row terminal panel for DIN rail
- ST8001:** Cable for connecting APCI-8008 and OPMF, 50-pin.

*Preliminary product information